



TAI-SAW TECHNOLOGY CO., LTD.

No. 3, Industrial 2nd Rd., Ping-Chen Industrial District,
Taoyuan, 324, Taiwan, R.O.C.

TEL: 886-3-4690038 FAX: 886-3-4697532

E-mail: tstsales@mail.taisaw.com Web: www.taisaw.com

Approval Sheet For Product Specification

Issued Date: 2/06/2009 (REV. NO: 1)

Product Name: SMD 5.0x3.2 8.000MHz Crystal Unit

TST Parts No.: TZ1545A

Customer Parts No. : _____

Company: _____
Division: _____
Approved by: _____
Date: _____

Checked by: Ann Liu 

Approval by: Robert Chang 

Date: 2/06/2009



TAI-SAW TECHNOLOGY CO., LTD.
SMD 5.0x3.2 8.000MHz Crystal Unit

MODEL NO.: TZ1545A

REV. NO.: 1

Revise:

Rev.	Rev. Page	Rev. Account	Date	Ref. No.	Reviser
1	N/A	Initial release	2/06/09'	N/A	Ann Liu



TAI-SAW TECHNOLOGY CO., LTD.

SMD 5.0x3.2 8.000MHz Crystal Unit

MODEL NO.: TZ1545A

REV. NO.: 1

Features:

- Surface Mount Hermetic Package
- Excellent Reliability Performance
- Good Frequency Perturbation and Stability over temperature
- Ultra Miniature Package

RoHS Compliant
Lead free
Lead-free soldering

Description and Applications:

Surface mount 5.0mmx3.2mm crystal unit for use in wireless communications devices, especially for a need of ultra miniature package for mobility.

Electrical Specifications:

TZ1545A	Specification
Nominal Frequency	8.000000 MHz
Mode of Oscillation	Fundamental
Storage Temperature Range	-50°C to +85°C
Operating Temperature Range	-40°C to +85°C
Frequency Stability over Operating Temperature	+/-20 ppm (referred to the value at 25°C)
Frequency Make Tolerance (FL)	+/-10 ppm @ 25°C +/- 3°C
Equivalent Series Resistance (ESR)	200 Ω max
Nominal Drive Level	50 uW max.
Shunt Capacitance (Co)	5 pF max
Load Capacitance (CL)	18 pF
Insulation Resistance	500 MΩ min./DC 100V
Marking	Laser Marking
Unit Weight	0.037+/-0.005g

Mechanical Dimensions (mm):

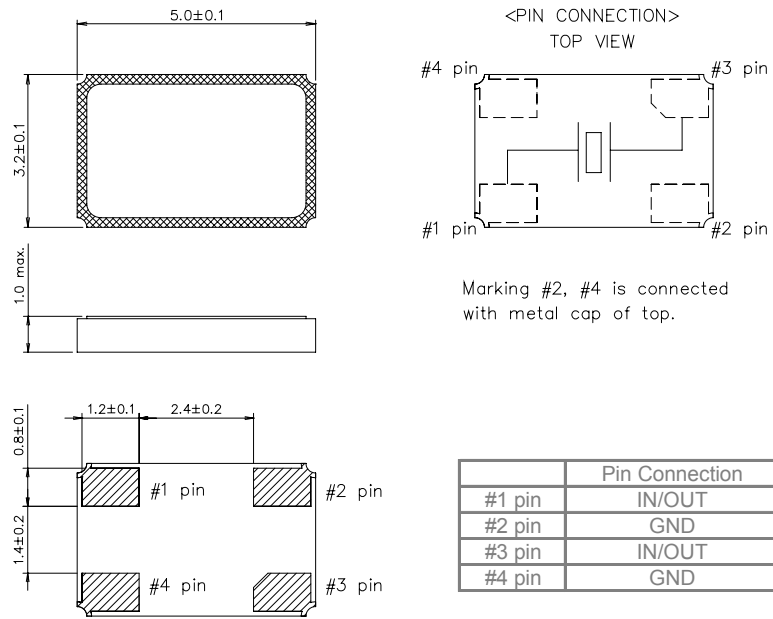

Recommended Land Pattern: (unit: mm)

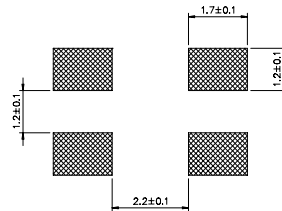

Marking:

Line 1: Frequency (8.000)

Line 2: TST Logo + Crystal Product Code + Date Code

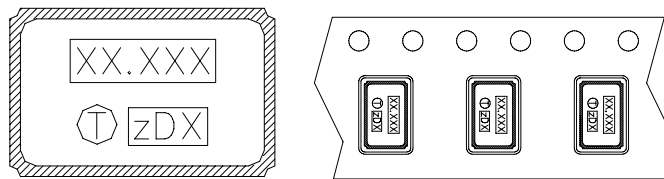

Product Code Table

Year	2008	2009	2010	2011
	2012	2013	2014	2015
Product code	<u>Z</u>	Z	Z	<u>Z</u>

Date Code Table

WK01	WK02	WK03	WK04	WK05	WK06	WK07	WK08	WK09	WK10	WK11	WK12	WK13
A	B	C	D	E	F	G	H	I	J	K	L	M
WK14	WK15	WK16	WK17	WK18	WK19	WK20	WK21	WK22	WK23	WK24	WK25	WK26
N	O	P	Q	R	S	T	U	V	W	X	Y	Z
WK27	WK28	WK29	WK30	WK31	WK32	WK33	WK34	WK35	WK36	WK37	WK38	WK39
a	b	c	d	e	f	g	h	i	j	k	l	m
WK40	WK41	WK42	WK43	WK44	WK45	WK46	WK47	WK48	WK49	WK50	WK51	WK52
n	o	p	q	r	s	t	u	v	w	x	y	z

Reel Dimensions (mm):

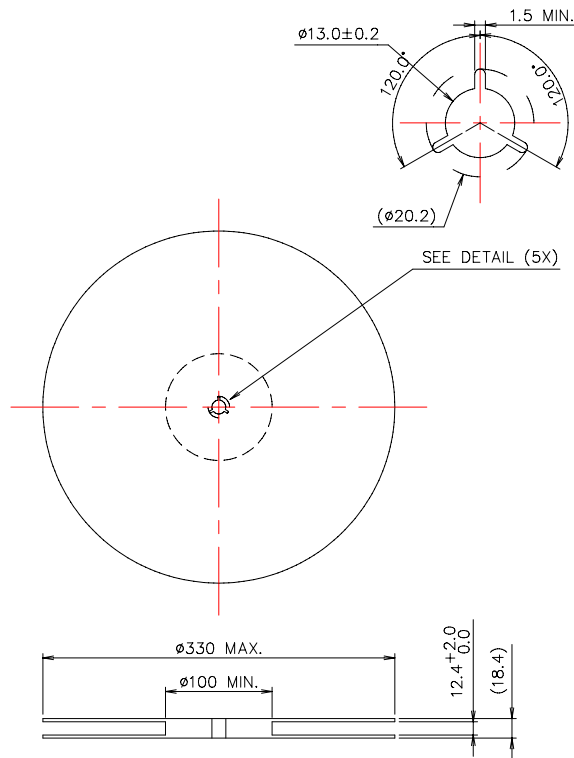

Tape Dimensions (mm):

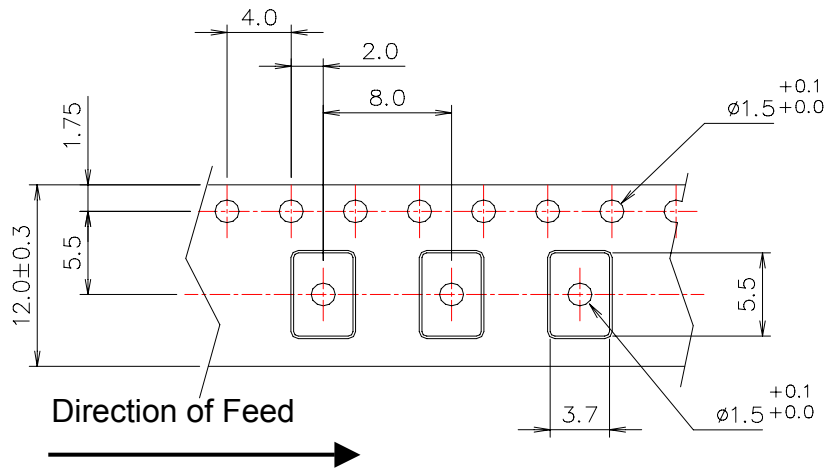

[NOTE]:

1. Unless otherwise specified tolerance on dimension +/-0.1 mm.
2. Material: conductive polystyrene with color black.
3. 10 pitch cumulative tolerance +/-0.2 mm.

Packing Quantity/Packing:

3K pcs maximum per reel

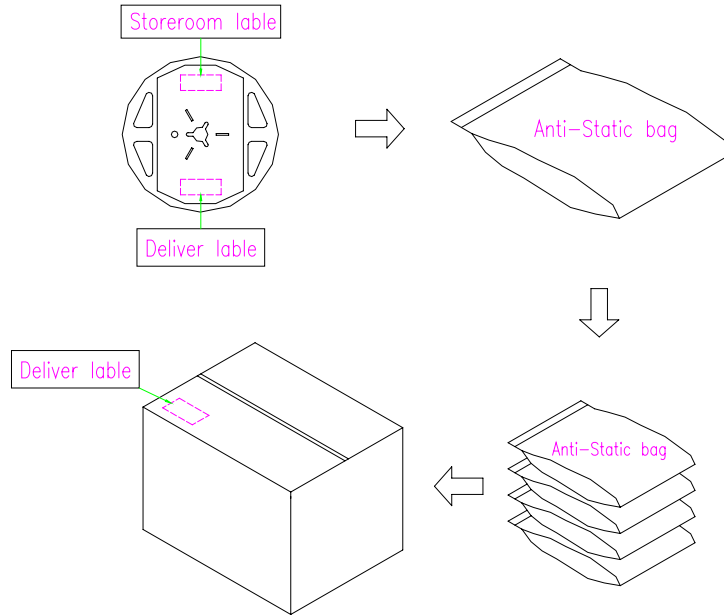

Deliver package carton
 1. L36xW35xH21cm-10 reel max.
 2. L38xW36xH32cm-15 reel max.

Reflow Profile:

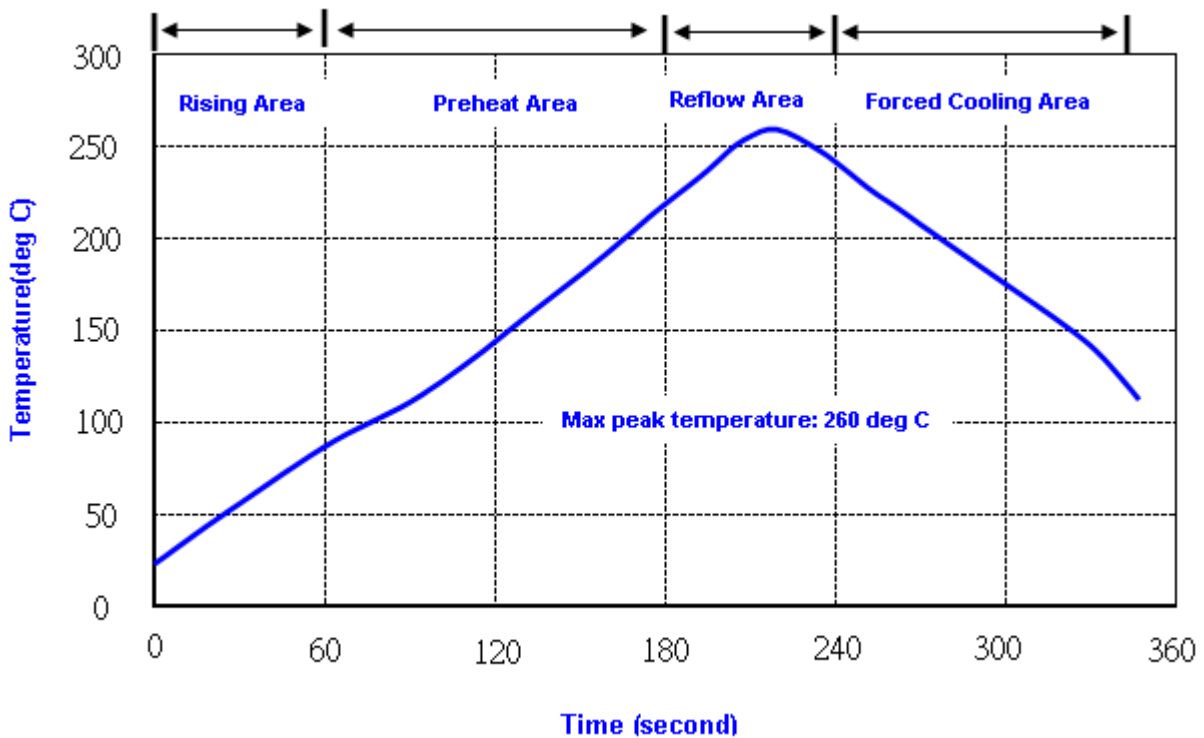

Note: 1. Max peak temperature: 260+/-5 deg C; Time: 10+/-2 sec
2. Temperature: 217+/-5 deg C; Time: 90~100 sec

Reliability Specifications

Test name	Test process / method	Reference standard
Mechanical characteristics		
resistance to Soldering heat (IR reflow)	Temp./ Duration : 260°C /10sec ×2 times Total time : 4min.(IR-reflow)	EIAJED-4701 -300(301)M(II)
Vibration	Total peak amplitude : 1.5mm Vibration frequency : 10 to 55 Hz Sweep period : 1.0 minute Vibration directions : 3 mutually perpendicular Duration : 2 hr / direc.	MIL-STD 202F method 201A
Mechanical Shock	directions : 3 impacts per axis Acceleration : 3000g's, +20/-0 % Duration : 0.3 ms (total 18 shocks) Waveform : Half-sine	MIL-STD 202F method 213C
Solderability	Solder Temperature:265±5°C Duration time: 5±0.5 seconds.	MIL-STD 883G method 2003
Environmental characteristics		
Thermal Shock	Heat cycle conditions -55 °C (30min) ↔ 125 °C (30min) * cycle time : 10 times	MIL-STD 883G method 1010.7
Humidity test	Temperature : 70 ± 2 °C Relative humidity : 90~95% Duration : 96 hours	MIL-STD 202F method 103B
Dry heat (Aging test)	Temperature : 125 ± 2 °C Duration : 168 hours	MIL-STD 883G method 1008.2 condition C
PCT test	Pressure: 2.06kg/cm ² (2.03*10 ⁵ pa) Temperature : 121 ± 2 °C Relative humidity : 100% Duration : 24 hours	EIAJED-4701-3 B-123A